

# **MDF Rose Engine Lathe 2.0**

## **with Stepper Motor Drive**

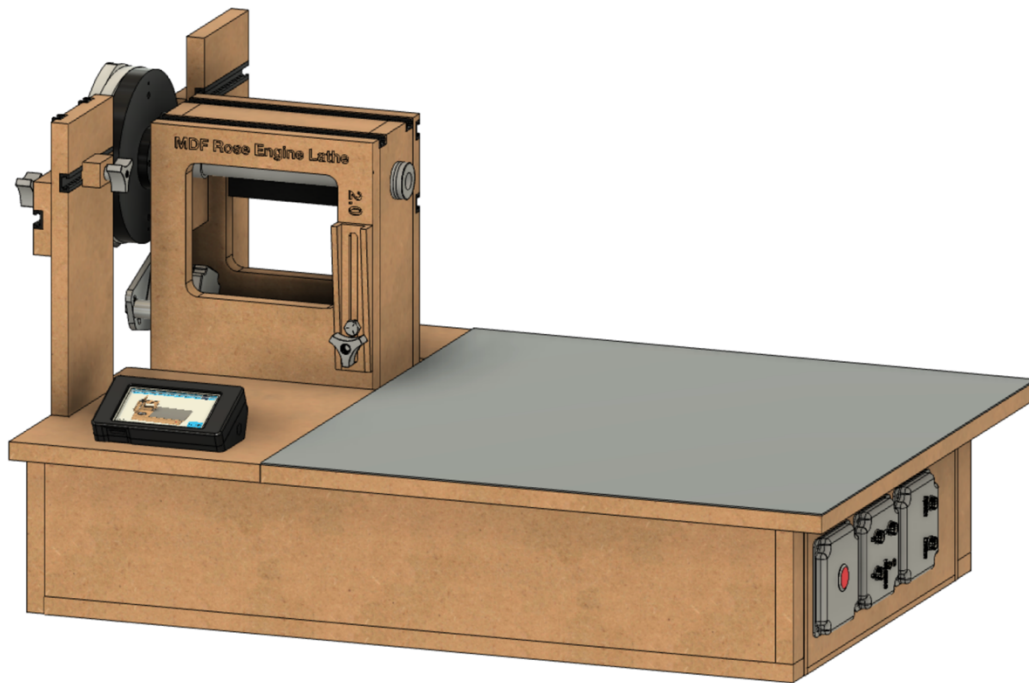

# **Instructions for Building Jigs, Fixtures, & Add-Ons**

## **Volume 3**

**Version 1.7**  
**09 February 2023**

# MDF Rose Engine Lathe 2.0

## Jigs, Fixtures, and Add-Ons

This document is intended to help one familiar with the MDF rose engine to easily build the identified jigs, fixtures, and add-ons. You can purchase these from us at [www.ColvinTools.com](http://www.ColvinTools.com), or build them yourself.

As you get started with building these jigs, fixtures, or add-ons to the MDF rose engine lathe, please consider making the machine exactly according to the outlined instructions. There are lots of ways you can modify this, and, quite frankly, the MDF rose engine encourages experimentation. But it is best to attempt those modifications after understanding how it works. Some ideas which sound grand may not appear so after understanding how the machine works (we speak from experience).

If you have any questions on the terminology in this document, check out the "Ornamental Turning Book of Knowledge" ([www.OTBoK.info](http://www.OTBoK.info)).

Throughout this document, I've tried to show the MDF in its native color of tan/brown. There are differences in the images I captured from the CAD drawing made, but those are not representative of the machine's differences.

The added pieces are typically shown in different colors to ensure they stand out from the MDF rose engine lathe.

Unless otherwise noted, the MDF is 3/4" thick.

If you have any questions, please contact us at [ColvinTools@Gmail.com](mailto:ColvinTools@Gmail.com).

Good luck and we hope you enjoy this machine as much as we.

Rich Colvin & Jack Zimmer

Permission is not granted to manufacture these for sale.

# MDF Rose Engine Lathe 2.0

## Jigs, Fixtures, and Add-Ons

### Table of Contents

<b>Spherical Slide .....</b>	<b>4</b>
<i>Bill of Materials.....</i>	<i>5</i>
<i>Cutout &amp; Machining Instructions.....</i>	<i>7</i>
<i>Wiring Instructions.....</i>	<i>14</i>
<i>Assembly Instructions.....</i>	<i>15</i>
<i>Further Instructions.....</i>	<i>18</i>
<i>Usage Notes.....</i>	<i>19</i>

## Spherical Slide

The spherical slide for the MDF Rose Engine Lathe 2.0 is shown in the picture to the right.

The base replaces the original bottom piece on the cross-slide as shown in the pictures to the right and below.

Details for building and assembling this follow the bill of materials.

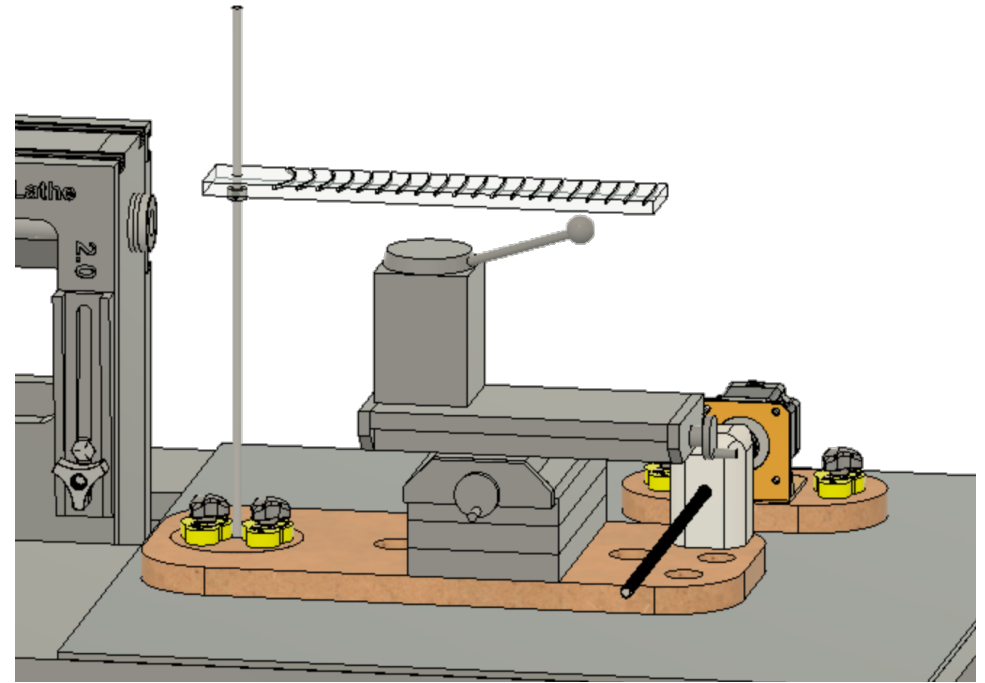

**Setup for use as a spherical slide**

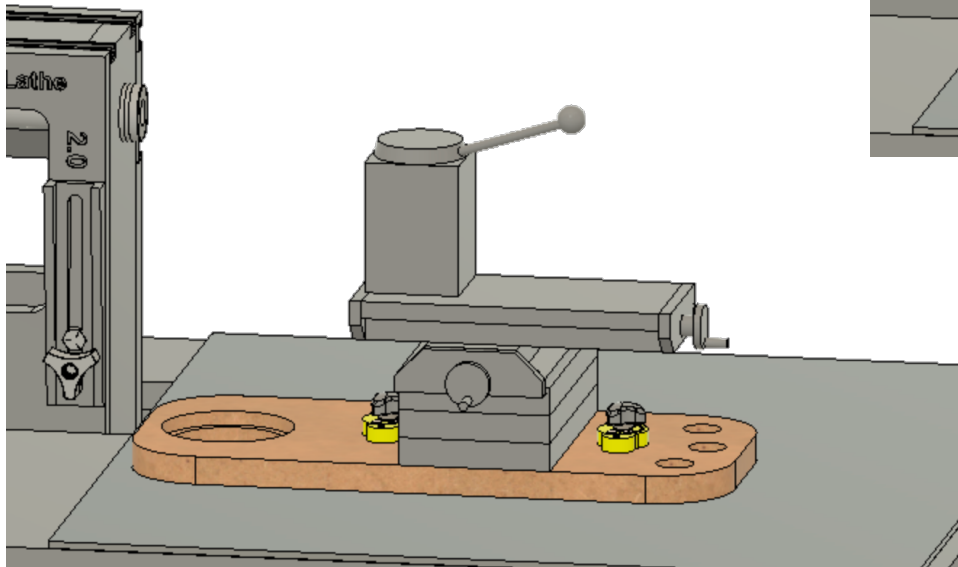

**Setup for use as a cross-slide**



# MDF Rose Engine Lathe 2.0

## Jigs, Fixtures, and Add-Ons

### Bill of Materials

Parts required for building this are below.

Item #	Item	Qty	Source	Source Part Number	Comments
	<b>Wood, Plate, and Rods</b>				
101	MDF, 3/4" thick				
102	UHMW Polyethylene Square Rod, 2" x 2" rod		Amazon		Size was 2.4" x 2.4" x 7.9" as purchased from Amazon
103	Plexiglass, 1/4" thick				Approximately 2" x 12" is needed
	<b>Purchased Components</b>				
201	MagSwitch MagJig 95	4-6	Amazon		
202	NEMA 23 Stepper Motor Steel Mounting Bracket	1	Amazon		
203	Screw, 1/4"-20	1	McMaster-Carr	91772A540	These are used to attach the Stepper Motor Mounting Bracket (#202) to the MDF block.
204	Fender Washer, 1/4"	1	McMaster-Carr	91525A120	
205	Lock nut, 1/4"	1	McMaster-Carr	95615A120	
206	Coupler, 8mm/8mm	1	Amazon		Used to attach the spindle on the stepper motor (#202) to the leadscrew (#207).
207	Leadscrew, T8, 300mm long	1	Amazon		2mm pitch, 4 start; for a 3D printer. Comes as a set with #208
208	Leadscrew nut, T8	1	Amazon		2mm pitch, 4 start Comes as a set with #207
209	Screws	4			Used to attach the leadscrew nut to the push point (made from #102).
210	Rod, 1/4" dia., 15" long	1			Used for the indicator arm.
211	Collar	1	McMaster-Carr	6432K12	1/4" ID, 1/2" OD. Used for the indicator arm.

## MDF Rose Engine Lathe 2.0 Jigs, Fixtures, and Add-Ons

Item #	Item	Qty	Source	Source Part Number	Comments
212	Stepper Motor, NEMA 23	1	StepperOnline	23HS30-30045	For the spindle drive: NEMA 23 bipolar 1.8°, 1.9 Nm, 2.8A, 3.2V, 57mm x 57mm x 76 mm
213	GX-16/ 4 Plug	1	Amazon		May come as a pair: socket and plug
214	Cable – 20 AWG/4, stranded		Amazon		18-24 inches needed
215	Screws, M5-080	4	McMaster-Carr	91239A228	Used to attach the stepper motor (#212) to the stepper motor bracket (#202)
216	Nuts, M5-080	4	McMaster-Carr	90592A095	

# MDF Rose Engine Lathe 2.0

## Jigs, Fixtures, and Add-Ons

### Cutout & Machining Instructions

#### Cross-Slide Base

The **cross-slide base** is made from  $\frac{3}{4}$ " MDF. Dimensions are as shown.

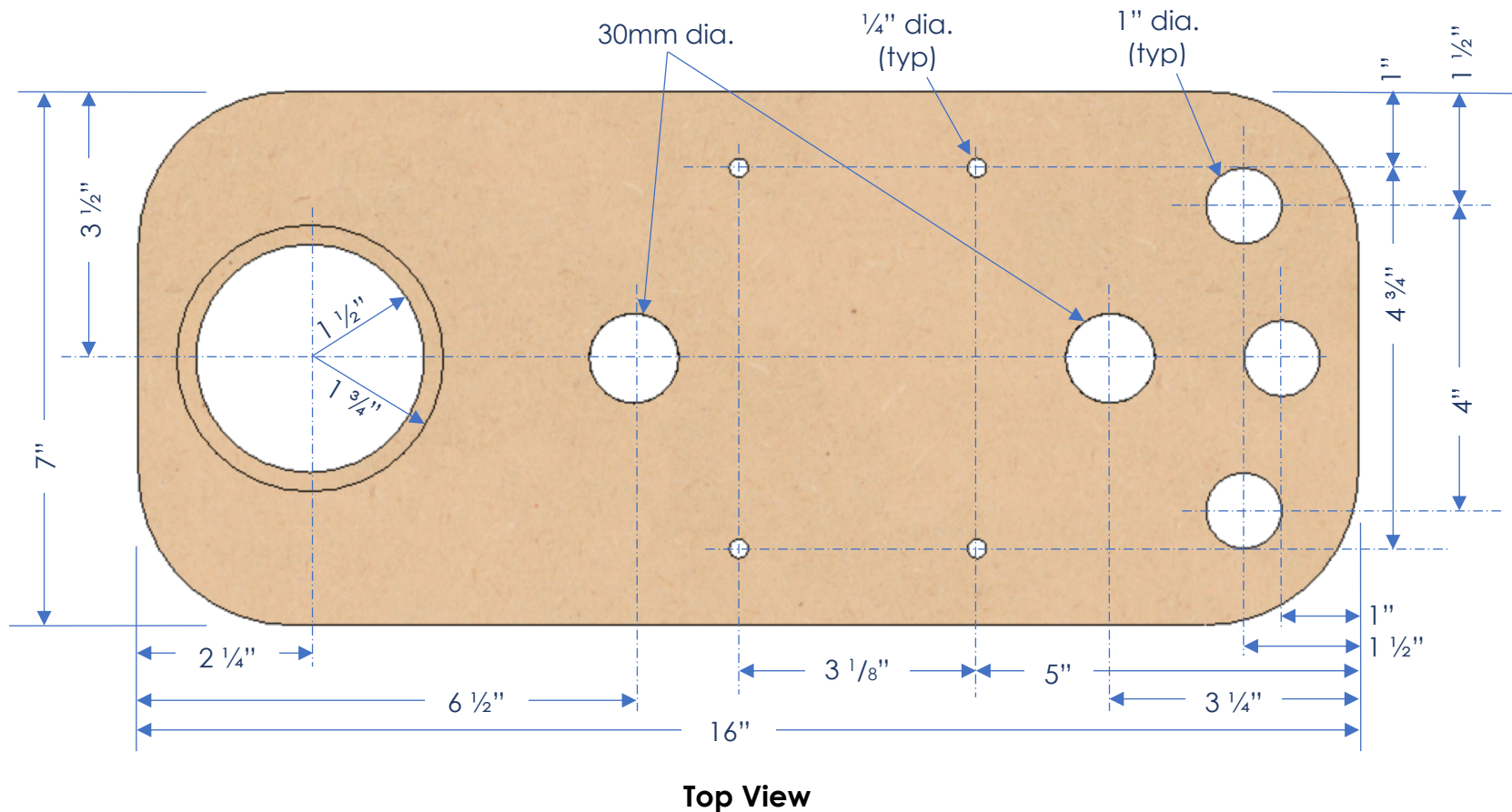

The hole on the left is cut so that the 1 3/4" diameter hole is halfway thru ( $\frac{3}{8}$ " deep).

## MDF Rose Engine Lathe 2.0 Jigs, Fixtures, and Add-Ons

The four holes for the  $\frac{1}{4}$ " screws need to have space for the screw heads. Drill space for these using a  $\frac{1}{2}$ " bit. They need to be  $\frac{1}{4}$ " –  $\frac{3}{8}$ " deep.

$\frac{1}{2}$ " dia.  
 $\frac{3}{8}$ " deep  
(typ)

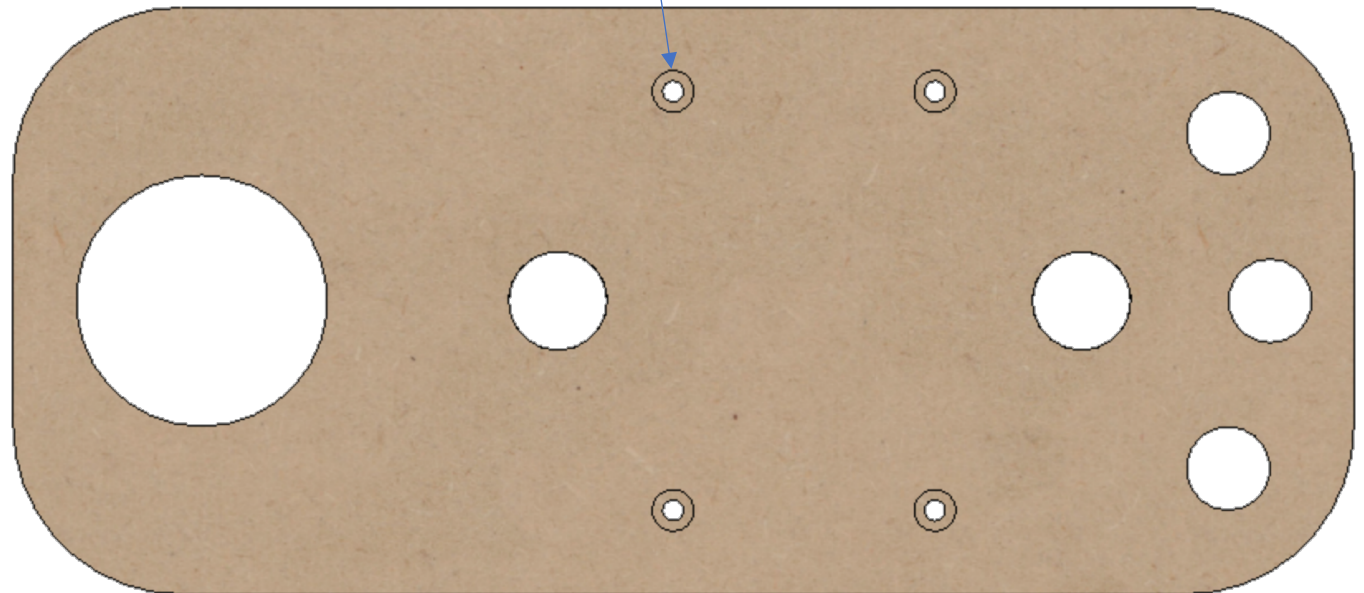

**Bottom View**

# MDF Rose Engine Lathe 2.0 Jigs, Fixtures, and Add-Ons

## Cross-Slide Pivot Point

The **cross-slide pivot point** is made from  $\frac{3}{4}$ " MDF. Dimensions are as shown.

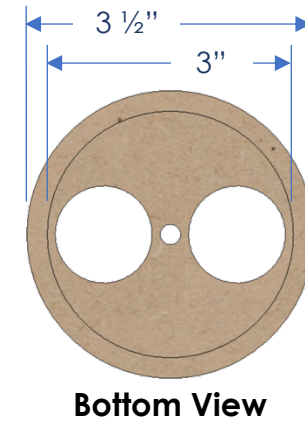
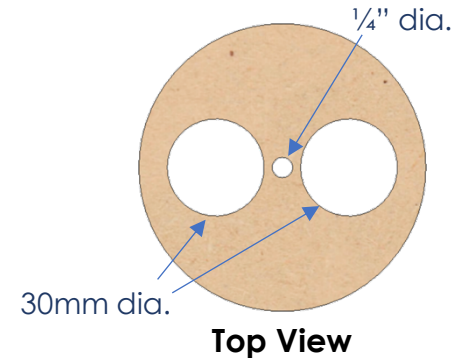

### **Problem Solving Note:**

If you find that, when using this jig, the mag switches are engaged and this piece rotates when the swing arm is rotating, remove a small bit of material on this side.



# MDF Rose Engine Lathe 2.0

## Jigs, Fixtures, and Add-Ons

### Motor Base

The **motor base** is made from  $\frac{3}{4}$ " MDF. Dimensions are as shown.

The hole for the  $\frac{1}{4}$ " screw needs to have space for the screw head. Drill space for this using a  $\frac{1}{2}$ " bit. It needs to be  $\frac{1}{4}$ " –  $\frac{3}{8}$ " deep.

This hole is for attaching the stepper motor bracket.

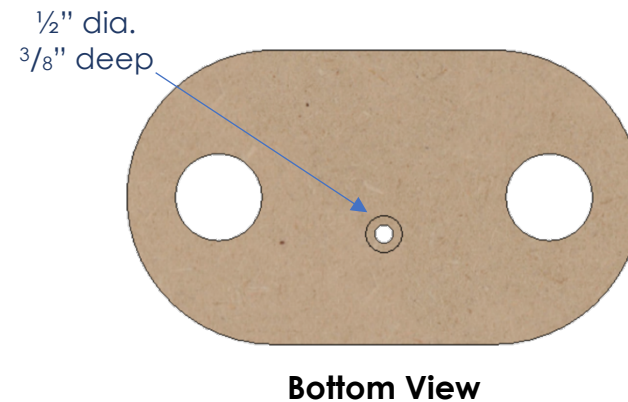
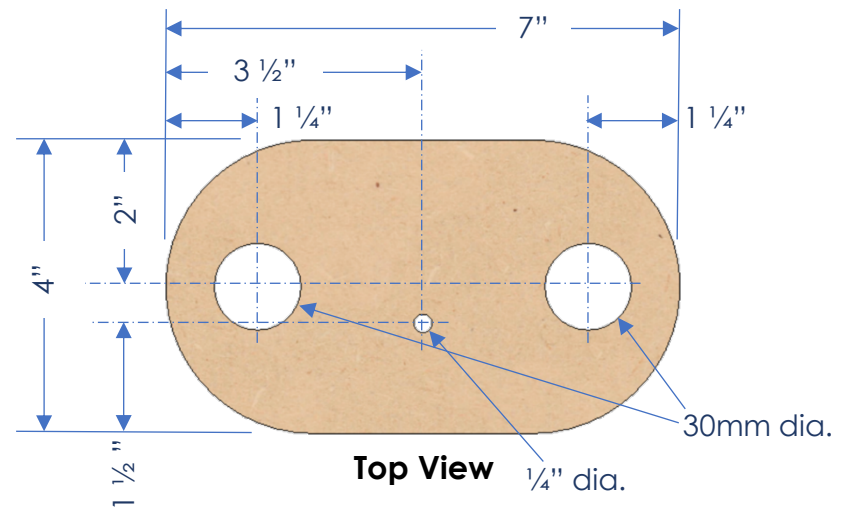

# MDF Rose Engine Lathe 2.0

## Jigs, Fixtures, and Add-Ons

### Push Point

The **push point** is made from UHMW polyethylene bar stock. The pictures here show it with the lead screw nut attached (#208, the brass part shown). Dimensions are as shown.

The 2" x 2" width of the stock is not terribly critical. It could be slightly bigger or smaller.

The critical dimensions are:

- The tenon must be no longer than  $\frac{3}{4}$ " or it will protrude below the MDF for the cross-slide base.
- The  $\frac{3}{8}$ " hole must be 1  $\frac{1}{2}$ " above MDF. This is to align it with the stepper motor's spindle.

When making the tenon, it is useful to round off the corners as noted in the picture below. This reduces the chance for any interference of this with the cross-slide.

Round the corners off, keeping a flat large enough for the lead screw nut.

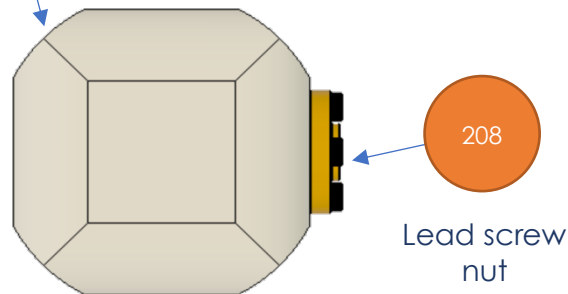

**Top View**

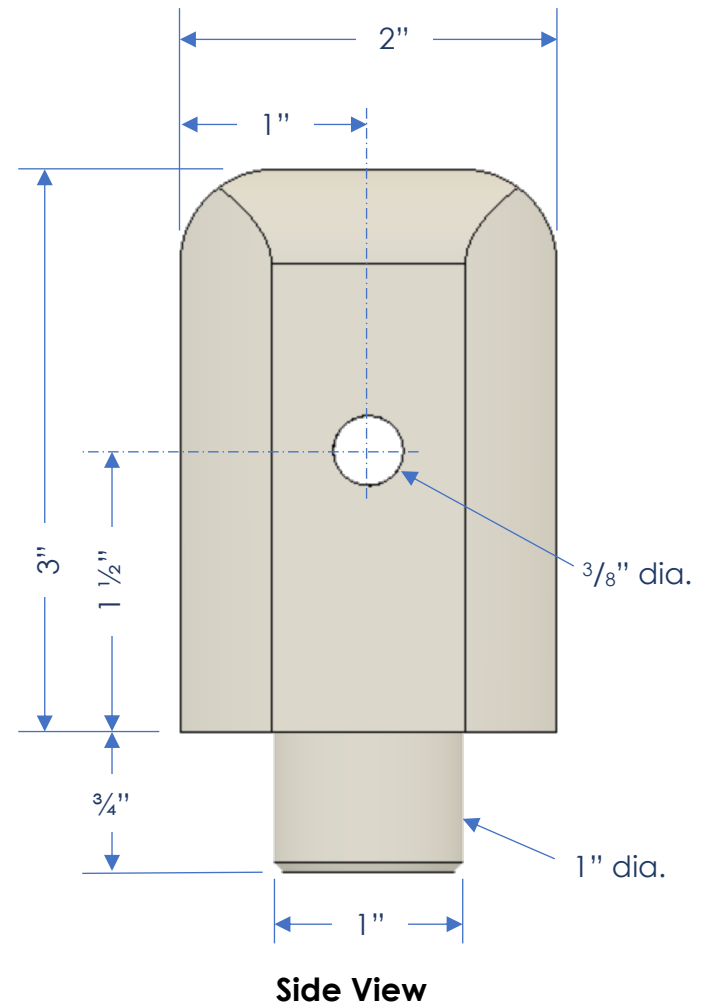

# MDF Rose Engine Lathe 2.0

## Jigs, Fixtures, and Add-Ons

### Indicator Arm

The **indicator arm** is made from  $\frac{1}{4}$ " plexiglass or similar transparent material. Dimensions are as shown.

The lines are concentric circles around the radius. The lines shown are added to the plexiglass using a permanent marker.

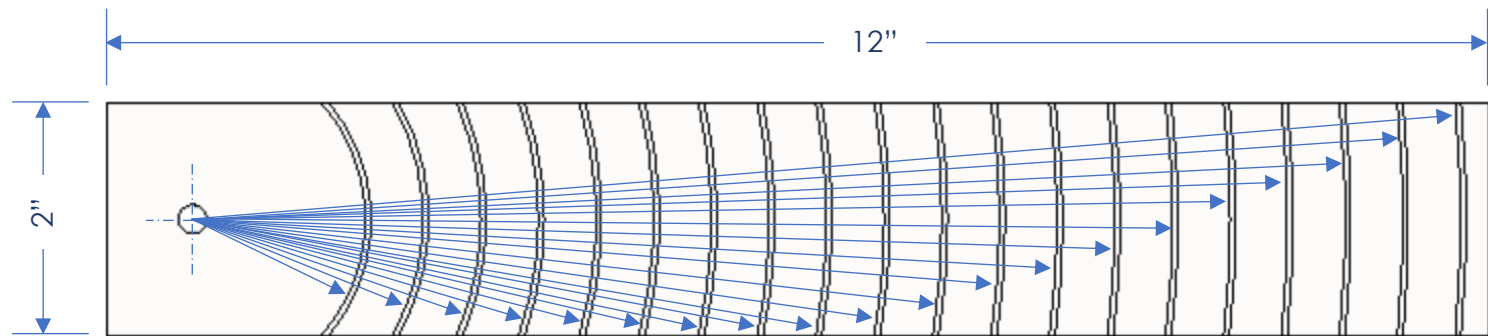



## MDF Rose Engine Lathe 2.0 Jigs, Fixtures, and Add-Ons

### Stepper Motor Bracket

Drill a  $\frac{1}{4}$ " hole thru the mounting bracket on the base. This hole is used for allowing the bracket to rotate as the motor moves during the spherical turning.

The location for the hole is not terribly critical. As shown, it is:

- Centered left-to-right
- Slightly forward towards the stepper motor's axle end (the bracket is 65mm x 65mm).

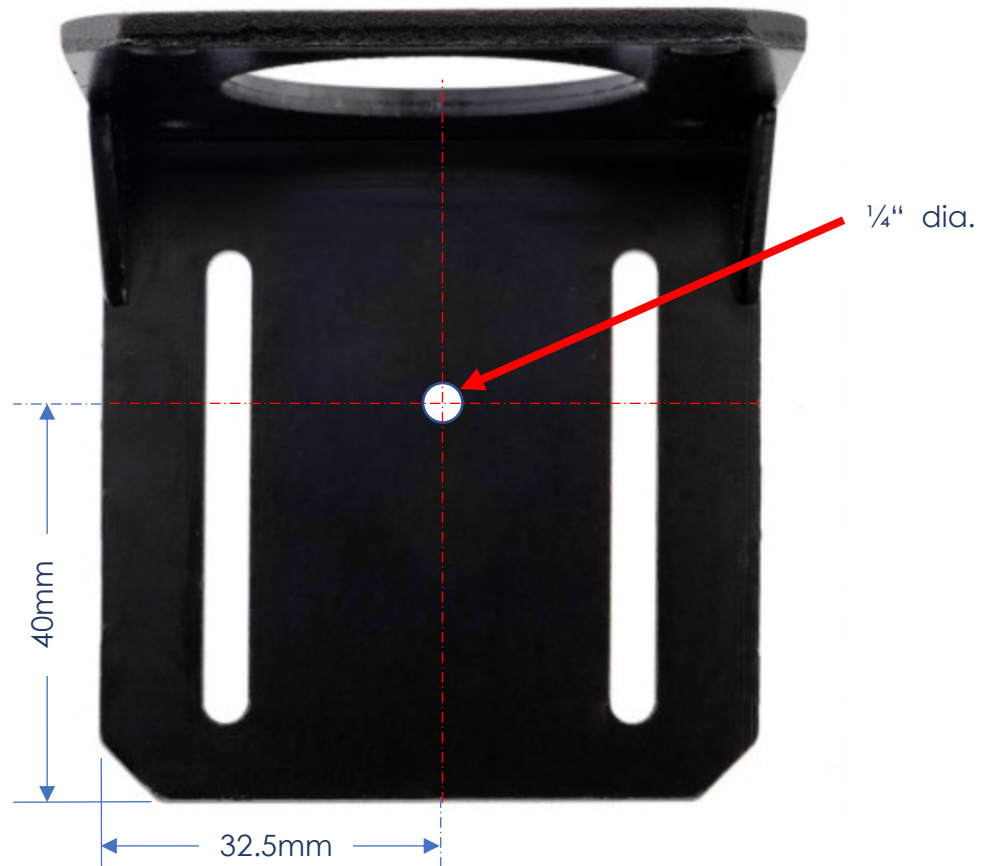

# MDF Rose Engine Lathe 2.0

## Jigs, Fixtures, and Add-Ons

### Wiring Instructions

#### Stepper Motor

The stepper motor is connected to the controls box via a GX-16/4 plug (#213). Stepper motor wire colors shown are for the StepperOnline motors. Check that the one you use matches for the connection needed.

Stepper Motor	Stepper Motor Wire	Cable Wire Color	GX-16/4 Pin
A+	Black	Black	1
A-	Green	Yellow	2
B+	Red	Red	3
B-	Blue	White	4



Conductor Type	Stranded copper
Conductor Size	20 AWG
Cable Size	4 conductors / cable
Cable Length	18-24 inches

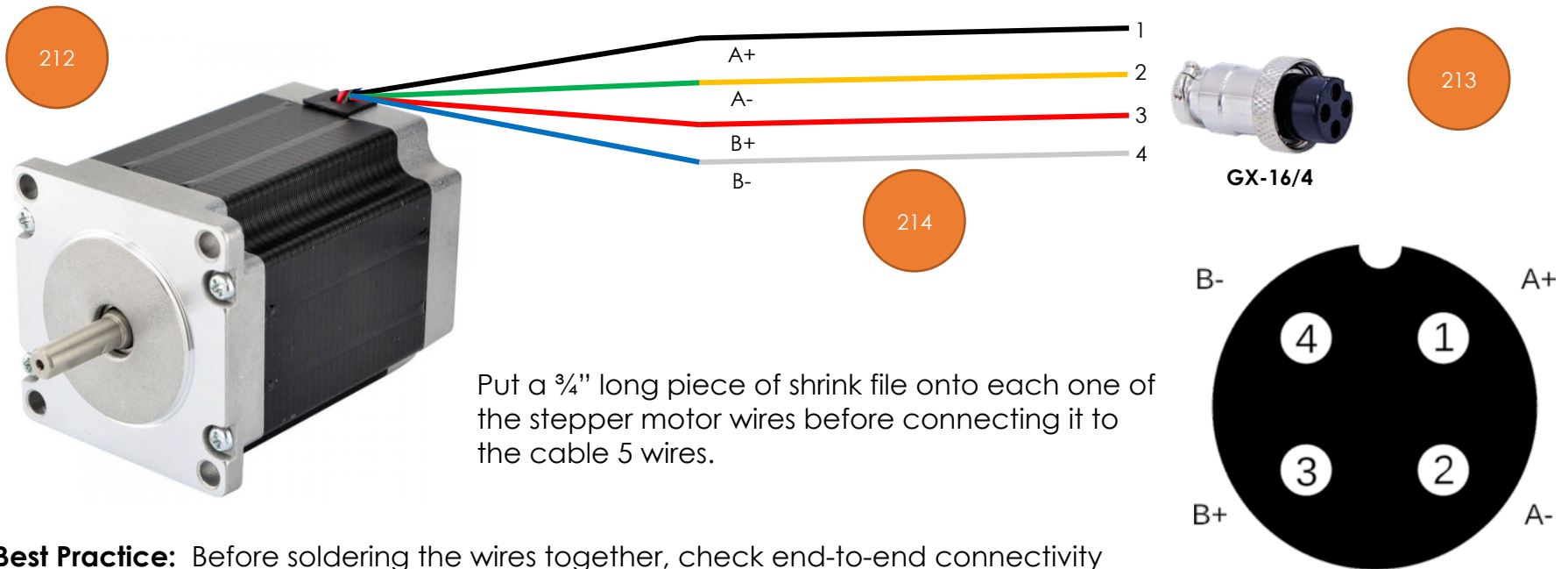

**Best Practice:** Before soldering the wires together, check end-to-end connectivity

# MDF Rose Engine Lathe 2.0

## Jigs, Fixtures, and Add-Ons

### Assembly Instructions

#### Cross-Slide Base

The assembled parts are shown as below.

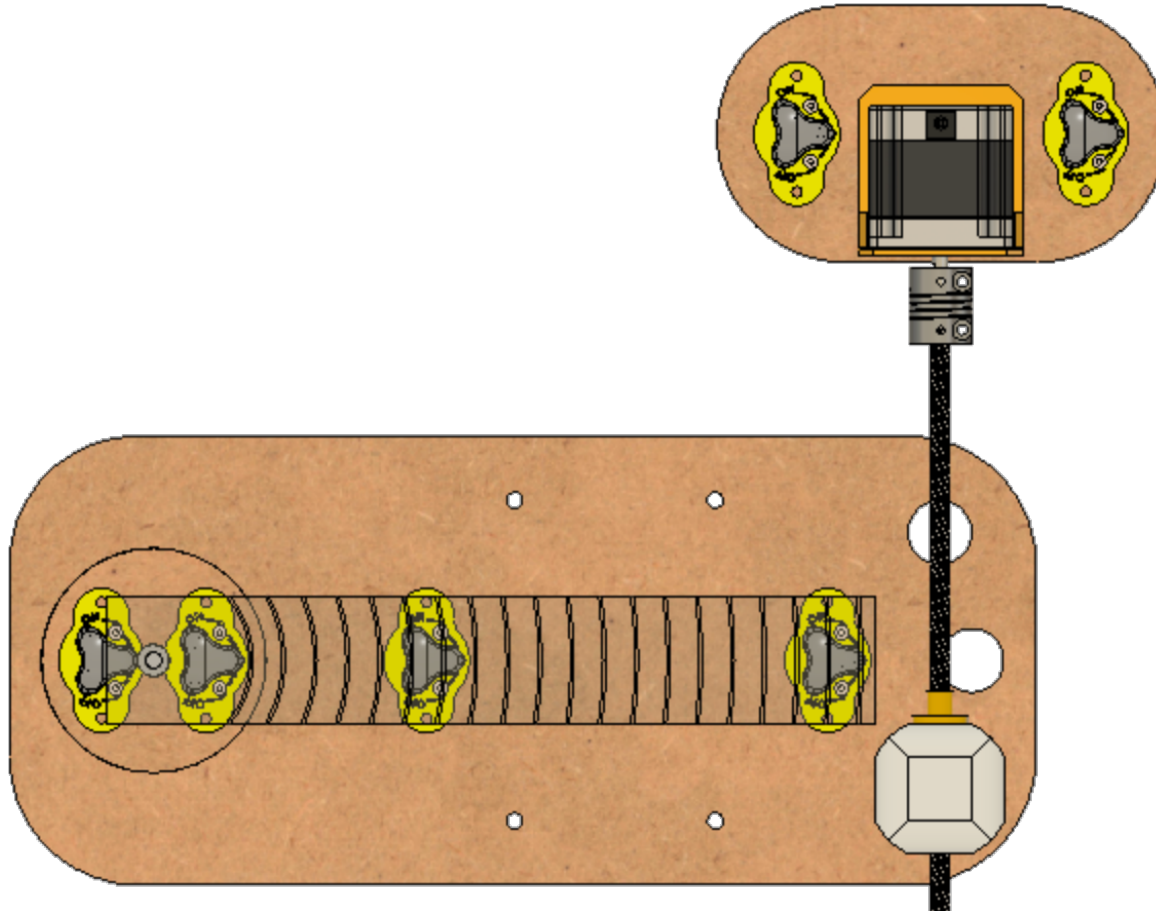

## MDF Rose Engine Lathe 2.0 Jigs, Fixtures, and Add-Ons

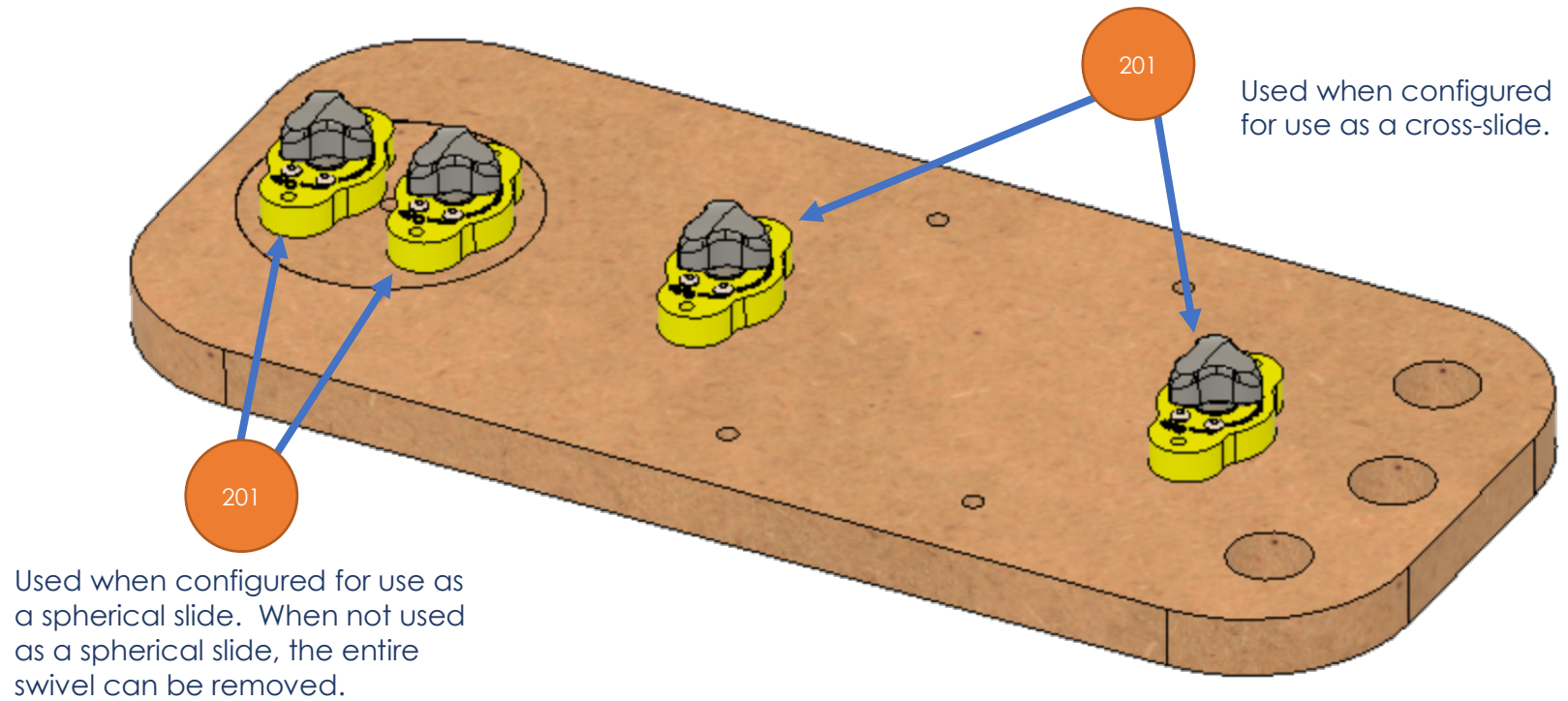

## MDF Rose Engine Lathe 2.0 Jigs, Fixtures, and Add-Ons

### Motor Base

The assembled parts are shown as below.  
(The screws attaching the stepper motor to the stepper motor bracket are not shown. 4 of those are needed.)

When attaching the stepper motor bracket (#202) to the MDF block, be sure the screw is not too tight. The stepper motor needs to be able to swivel freely.

The leadscrew can be left attached to the coupler or attached when used.

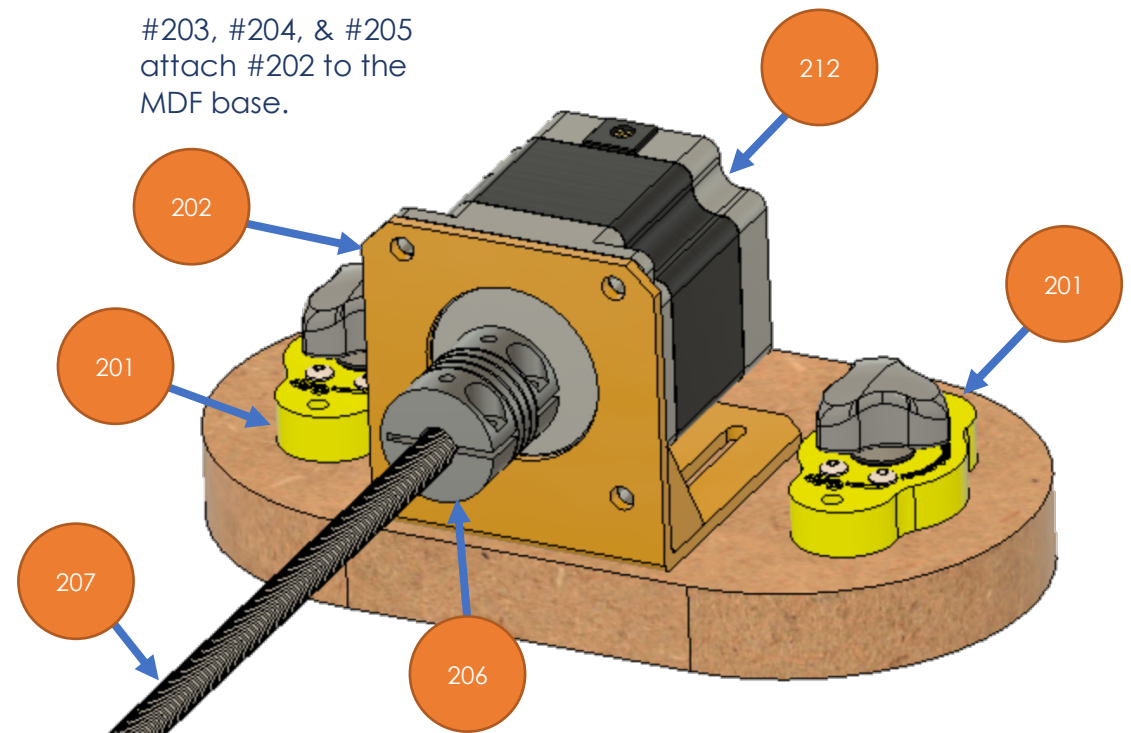

# MDF Rose Engine Lathe 2.0

## Jigs, Fixtures, and Add-Ons

### Further Instructions

I advise adding a label to this jig to make it easier to setup with the Control System for Multiple Stepper Motors. The relevant information for using this with either M3 or M4 is outlined below.

### Linear Movement

Linear movement is not recommended; however, if you choose that approach, the values you need are below.

Distance/360      0.31496"  
8mm

### Radial Movement

As the rotation arm for the cross-slide base has a radius which is 12.5" long,

Circumference of cross-slide arm's movement =  $12.5" \times 2 \times \pi = 78.53982"$

And the leadscrew moves 0.31496" (8mm) per turn as the stepper motor rotates the leadscrew, it moves the circumference by 0.31496". Thusly, each rotation of the leadscrew moves the cross-slide,

$$\frac{0.31496"}{78.53982"} \times 360^\circ = 1.44367^\circ$$

The gear ration (rounded to 2 decimal places) is thusly,

$$\frac{360^\circ}{1.44367^\circ} = 249.36$$

Spindle	Preferences	Back
Z Axis	<b>Motor 4</b>	Limits
X Axis	Microsteps <input type="text" value="32"/>	Returns
Motor 3	Steps/360 <input type="text" value="200"/>	More
Motor 4	Polarity High <input checked="" type="radio"/> Low <input type="radio"/>	
	<input checked="" type="radio"/> Radial <input type="radio"/> Linear      Gear Ratio <input type="text" value="15"/>	
	Distance/360 <input type="text" value=".0175"/>	
	Leadscrew Left <input checked="" type="radio"/> Right <input type="radio"/>	

When setting this up for radial movement, use this value for the Gear Ratio.

**249.36**



# MDF Rose Engine Lathe 2.0

## Jigs, Fixtures, and Add-Ons

### Usage Notes

When using this jig, there will be backlash: the tenon for the Push Point is not a machined fit with the cross-slide base.

The approach taken was to keep the cost down for building this jig, and to make it easy to make.

Plan for this backlash in your movement of the cutter.

### Why Radial is Recommended

When using this jig with the Control System for Multiple Stepper Motors, if the M4 axis is set to radial:

- Use ONE to quickly move the slide around
- Use INDEX to move the cutter a set amount around the sphere (and to rotate the sphere via the axis)
- Use SYNC to synchronize the jig's movement with the spindle
- These functions can be used for some designs which would be nice
  - RECIP
  - ROSE
  - GREEK KEY
  - MULTISYNC

