

MDF Rose Engine Lathe 2.0 with Stepper Motor Drive

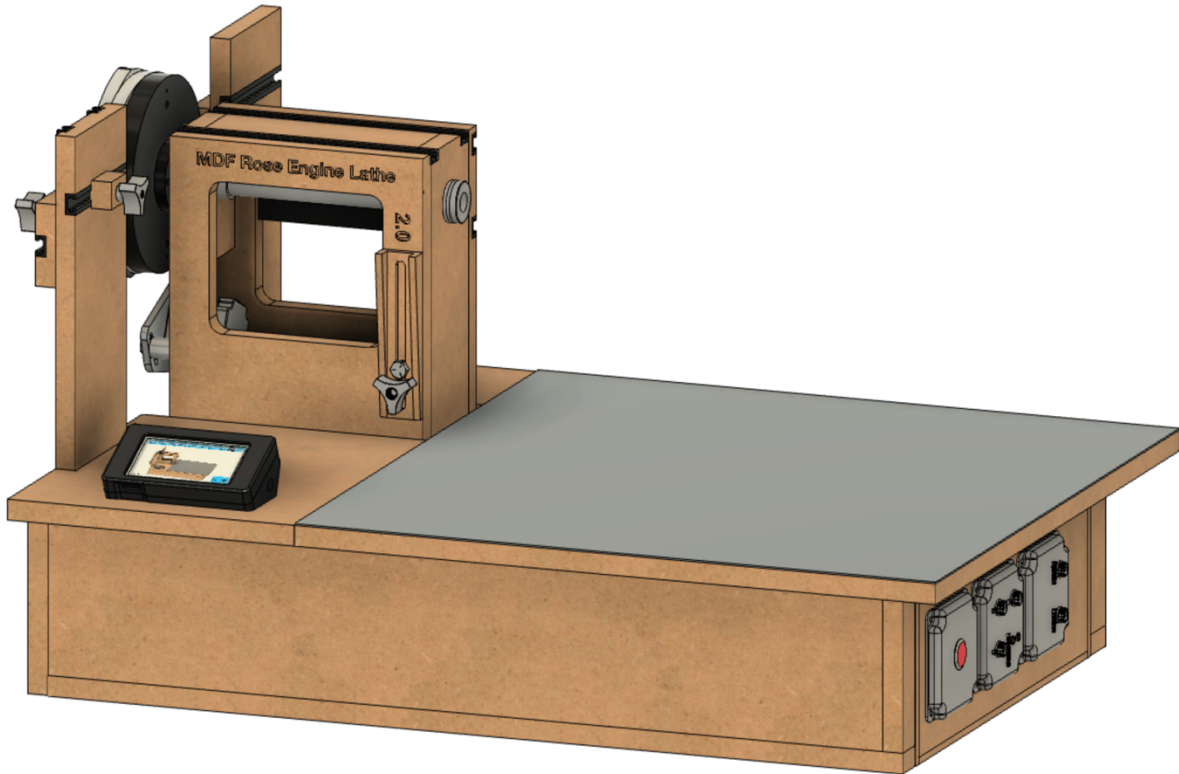

Instructions for Building Control System for Multiple Stepper Motors

Part 1 – General Information & Bill of Materials

**Version 4.0
01 August 2022**

MDF Rose Engine Lathe 2.0

Build Instructions – Control System for Multiple Stepper Motors

This document is intended to help one unfamiliar with the MDF rose engine to build one easily. It is designed to go with the kit you can purchase from www.ColvinTools.com.

There are some variations from the ideas documented by Jon Magill at www.rogueturner.com. Where this is the case, we have tried to document such changes and provide the reason for the change.

This document is designed to use a stepper motor for driving the spindle.

NOTE: This has been split into separate parts to accommodate some variations.

Part 1 General Information & Bill of Materials

Part 2 Case – as there are many options, this is being split out to separate documents for each case option.

2a MDF Case – You build yourself

Part 3 Electronics, including

- Soldering of the parts to the PCB
- Soldering of wires to the jacks & plugs
- Wiring the components together

If you have any questions, please contact us at ColvinTools@Gmail.com.

Good luck.

Rich Colvin & Jack Zimmer

MDF Rose Engine Lathe 2.0

Build Instructions – Control System for Multiple Stepper Motors

Table of Contents

Getting Started	4
Bill of Materials	5
Section 1 – Attaching the Stepper Motor to the Headstock	14
Optional Configurations	16
<i>Option 1: Less Functional Model</i>	16
<i>Option 2: Alternative Stepper Motor Drives</i>	17
<i>Option 3: Different Microcontroller</i>	18
<i>Option 4: Different Display</i>	19
Document Version History	20

MDF Rose Engine Lathe 2.0

Build Instructions – Control System for Multiple Stepper Motors

Getting Started

As you get started with building this machine, please consider making the machine according to the outlined instructions. There are a boatload of ways you can modify this, and, quite frankly, the MDF rose engine encourages experimentation, but it is best to attempt those modifications after understanding how it works. Some ideas which sound grand may not appear so after understanding how the machine works (we speak from experience).

If you have any questions on the terminology in this document, check out the “Ornamental Turning Book of Knowledge” (www.OTBoK.info).

This document outlines the approach for wiring this machine using:

1. Rose Engine Controller Spindle and Three Axes V002c printed circuit board
2. Nextion 4.3” HMI Display, model NX4827K043
3. Teensy 3.5 Microcontroller
4. DM542T Stepper Motor Drives

Standards are outlined in a companion document and are used for the compilation of this document.

Cautions

1. **Do not perform any changes to this system when the system is powered on.** Power down and unplug the system before attempting any work.
2. If your local electrical code requires for any differences from what is documented here, those requirements take precedence over this document.
3. If you feel uncomfortable with anything in these instructions, consider having a licensed electrician perform the work.

Please also note: Permission is not granted to manufacture these for sale.

The sequence of activities follows the layout of this document. That was done consciously. Changes to the sequence should be considered strongly before making changes.

MDF Rose Engine Lathe 2.0

Build Instructions – Control System for Multiple Stepper Motors



Bill of Materials

Parts required for building this are below. The item numbers are shown in the following drawings using an orange, circled number like the one to the right.

3



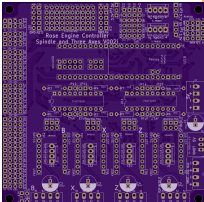
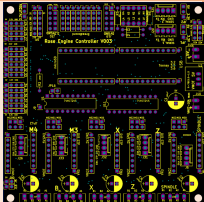
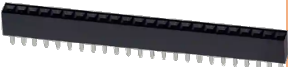







This is the complete BOM for all sections. It is provided completely here to allow for purchasing the parts. Other documents in this set show only the parts used in that respective document.

NOTE: Pictures shown in the table below are to help with identification. Sizes shown are not representative of the actual size.

Item #	Item	Qty	Source	Source Part Number	Comments
	Printed Circuit Board Assembly				
101	Printed Circuit Board (PCB) 	1	OSH Park	4Rose_002c_Gerbers copy	
101 v3	Printed Circuit Board (PCB) v3 	1	Seeed Studio	https://www.seeedstudio.com/5-axes-Rose-Engine-and-CNC-g-1367637	This is the newer version of the one in the prior line.
102	Header Sockets 	2	Digi-Key	S7022-ND	24 pins each Mfgr p/n PPTC241LFBN-RC Used to hold the Teensy on the PCB.
103	20-pin DIP sockets 	2	Digi-Key	ED3054-5-ND	
104	10 K Ω resistors 	8	Digi-Key	CF14JT10KoCT-ND	

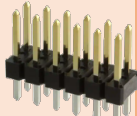

MDF Rose Engine Lathe 2.0

Build Instructions – Control System for Multiple Stepper Motors

Item #	Item	Qty	Source	Source Part Number	Comments
105	100 µF electrolytic capacitor 	1	LCSC	C59414	Mfgr p/n KM101M050F115A
106	74HCT245 Octal Bus Transceiver, 3-state 	2	Digi-Key	296-1612-5-ND	
107	R-78E5.0-1.0 DC/DC Converter 	1	Digi-Key	945-2201-ND	
108	Teensy 3.5 	1	PJRC	Teensy 3.5 pins	Be sure to get the one with the pins already soldered into place.
109	(Unused for this design)				
110	(Unused for this design)				
111	Header Connector, Vertical, 4 pins, 2.54mm pin spacing 	5	Digi-Key	WM4113-ND	Used to connect the PCB to: <ul style="list-style-type: none"> Stepper motor drives (4) Nextion Display (1) Molex p/n 0022272041
112	Header Connector, 90 degree, 4 pins, 3.50mm pin spacing 	1	Digi-Key	277-2419-ND	Used to connect power to the PCB. Phoenix Contact p/n 1844236
113	Header Connector, Vertical, 12 pins (6x2), 2.54mm pin spacing 	1	Digi-Key	609-5695-ND	Used to connect jacks for limit switches to the PCB. Amphenol ICC p/n 77313-101-12LF
114	Header Connector, Vertical, 2 pins, 2.54mm pin spacing 	1	Digi-Key	SAM12303-ND	Used for setting the power selection for the Nextion touch screen. Samtec p/n TSW-102-24-T-S
115	Mini Jumper 	1	Digi-Key	68786-302-ND	Used for setting the power selection for the Nextion touch screen. Amphenol p/n 68786-302. NOTE: original part, Amphenol p/n G89011020023DEU, is now obsolete.
116	Header Connector, Vertical, 4 pins (1x4), 2.54mm pin spacing 	4	Digi-Key	609-5676-ND	Used on V002i PCB to enable use of resistors. Amphenol ICC p/n 77311-101-04LF. NOTE: Only needed if using the V002i PCB.

MDF Rose Engine Lathe 2.0

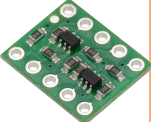

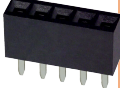

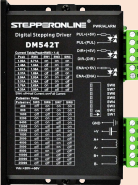

Build Instructions – Control System for Multiple Stepper Motors

Item #	Item	Qty	Source	Source Part Number	Comments
117	Header Connector, Vertical, 4 pins (2x2), 2.54mm pin spacing 	1	Digi-Key	609-5691-ND	Optional: Can be used to connect jacks for limit switches to the PCB. Amphenol ICC p/n 77313-101-04LF.
118	Logic Level Shifter, 4-Channel, Bidirectional 	1	Pololu	2595	Used on the PCB (item # 101) version 3
119	Header Connector, 90 degree, 2 pins, 3.50mm pin spacing 	1	Digikey	277-2416-ND	Used on the PCB (item # 101) version 3
120	Header Sockets 	2	Digi-Key	S6103-ND	5 pins each Mfgr p/n PPTCo51LFBN-RC. Used to hold the Pololu 2959 onto the PCB.

Item #	Item	Qty	Source	Source Part Number	Comments
Electrical Items					
201	AC/DC Power Supply - LRS-100-24 	1	Digi-Key	1866-3314-ND	
202	DM542T Stepper Driver 	4	StepperOnline	DM542T	



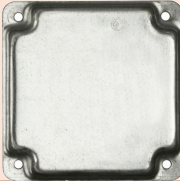



MDF Rose Engine Lathe 2.0

Build Instructions – Control System for Multiple Stepper Motors

Item #	Item	Qty	Source	Source Part Number	Comments
203	Nextion 4.3" Enhanced HMI 	1	ITEAD.cc	NX4827K043	If that model is not available, select the replacement which has: <ul style="list-style-type: none"> Resistive touch (vs. capacitance) Flash data storage space: 32MB or more EEPROM: 1024 bytes or more RAM: 8192 bytes or more Instruction buffer: 1024 bytes or more Resolution: 480×272 pixel <p>Use this with #601. The 7" model is #221.</p>
204	Terminal Block, 10 circuits, low profile 	1	Mouser	538-39100-1910	Used to distribute power from the LRS-100-24 (#201) to the other parts in the box. Molex p/n 39100-1910
205	Power Switch 	1			SPST Toggle
206	GX-16/ 4 Socket 	4	Amazon		Used to connect stepper motors to stepper motor drives. May come as a pair of sockets and plugs (i.e., including #214)
207	3.5mm Audio Jack, Female 	6			Used for connecting limit switches. NOTE: #220 is a very good alternative to use in lieu of this part.
208	Utility box cover, 2 gang 			Hubbell-Raco 804C	No longer using this – Use #219 instead.
209	Utility box cover, 1 gang 	1		Hubbell-Raco 861	
210	Utility box cover, 1 gang 			Hubbell-Raco 860	No longer using this – Use #219 instead.

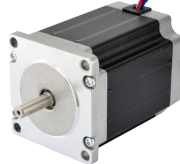

MDF Rose Engine Lathe 2.0



Build Instructions – Control System for Multiple Stepper Motors

Item #	Item	Qty	Source	Source Part Number	Comments
211	3/8 in. Twin-Screw Cable Clamp Connectors 	1			Used for the AC power cable.
212	Cord Grip 	1	McMaster-Carr	69915K47	Used for the cable to the 3D-printed case for the Nextion display. If hard wiring the cable to the main box, a 2d one of these is needed.
213	Stepper Motor 	1	StepperOnline	23HS30-30045	For the spindle drive: NEMA 23 bipolar 1.8°, 1.9 Nm, 2.8A, 3.2V, 57mm x 57mm x 76 mm
214	GX-16/ 4 Plug 	1	Amazon		Used for stepper motors. May come as a pair of sockets and plugs (i.e., including #206)
215	GX-12/ 4 Socket 	1	Amazon		Used for the Nextion touch screen display. May come as a pair of sockets and plugs (i.e., including #216)
216	GX-12/ 4 Plug 	1	Amazon		Used for the Nextion touch screen display in lieu of RJ-45 connectors. May come as a pair of sockets and plugs (i.e., including #215)
217	Connector Housing Receptacle, 2.54mm pin spacing 	5	Digi-Key	WM2002-ND	Used to connect the PCB to: <ul style="list-style-type: none"> Stepper motor drives (4) Nextion Display (1) Molex p/n 0022013047
218	Terminal Block Plug, 4 pins, Screw Terminals, 3.50mm pin spacing 	1	Digi-Key	277-2418-ND	Used to connect power to the PCB. Phoenix Contact p/n 1840382
219	Controls Face Plate, 3D printed	1	Colvin Tools		3D printing designs are at https://mdfre2.colvintools.com/3DPrint.html . <ul style="list-style-type: none"> Use version 2 with #207 3.5mm audio jacks Use version 3 with #220 3.5mm audio jacks
220	3.5mm Audio Jack, Female 	5	Digi-Key	839-1410-ND	Use these with the #219 Controls Face Plate (use version 3 of the templates the holes for this jack are bigger). They are significantly better quality than the generic ones I've found on Amazon or elsewhere. Bit more expensive too. Tensility p/n 54-00080.

MDF Rose Engine Lathe 2.0











Build Instructions – Control System for Multiple Stepper Motors

Item #	Item	Qty	Source	Source Part Number	Comments
221	Nextion 7" Intelligent HMI 	1	ITEAD.cc	NX8048P070-011R	<p>If that model is not available, select the replacement which has:</p> <ul style="list-style-type: none"> Resistive touch (vs. capacitance) Flash data storage space: 128 MB or more EEPROM: 1024 bytes or more RAM: 512 KB or more Resolution: 800×480 pixels <p>Use this with #602. Use this in lieu of #203 (4.3" model).</p>
222	Terminal Block Plug, 2 pins, Screw Terminals, 3.50mm pin spacing 	1	Digi-Key	277-9008-ND	<p>Used to connect power to the PCB. Phoenix Contact p/n 1840382</p> <p>Used on the PCB (item # 101) version 3</p>

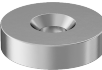
Item #	Item	Qty	Source	Source Part Number	Comments
	Cables				
301	Cabling – CAT 5 or higher				Used for the Nextion touch screen.
302	Cabling – 20 AWG/4, stranded				Used for signaling for the stepper motors and the stepper motor drives.
303	Cabling – 20 or 22 AWG/2, stranded or solid core				Used for low voltage, DC power.
304	Cabling – 16 AWG/3, stranded				Used for AC power. Can cut off the female end of a grounded extension cord.
305	Cable with Connector, 2 pin, 2.54mm pin spacing, 500mm long (19 1/2") 	3	Digi-Key	1175-1261-ND	Used for limit switches. Both ends have connectors, so cable will be cut in the center to make two each. CNC Tech p/n 810-10053-00050
	Cable, pre-crimped on one end for Molex connector (#217), 10" long, 28 AWG,				Used to connect the PCB to the GX-12/4 socket for the Nextion touch screen.
306	<ul style="list-style-type: none"> White 	1	Digi-Key	0008500113-10-W8-ND	Molex p/n 08500113-10-W8
307	<ul style="list-style-type: none"> Orange 	1	Digi-Key	0008500113-10-A8-ND	Molex p/n 08500113-10-A8
308	<ul style="list-style-type: none"> Green 	1	Digi-Key	0008500113-10-G8-ND	Molex p/n 08500113-10-G8
309	<ul style="list-style-type: none"> Blue 	1	Digi-Key	0008500113-10-L8-ND	Molex p/n 08500113-10-L8
310	Crimp Terminal 	16	Digi-Key	WM2312-ND	Used to connect the PCB to the DM542T stepper motor drives. Molex p/n 08550102



MDF Rose Engine Lathe 2.0

Build Instructions – Control System for Multiple Stepper Motors

Item #	Item	Qty	Source	Source Part Number	Comments
	Screws, etc.				
401	Nylon Spacer (Unthreaded) for #8 screw – 1/4" OD, 1/4" length 	4	McMaster-Carr	94639A293	Used to raise the PCB up off the MDF.
402	Brass Heat-Set Inserts for Plastic, #4-40, 0.170" 	4	McMaster-Carr	94459A260	If you take option #1 as outlined in part 2, you should use these. If not, they are not needed. These go with #403, below.
403	Screws, #4-40, 3/4" 	4	McMaster-Carr	97763A322	If you take option #1 as outlined in part 2, you should use these. If not, they are not needed. These go with #402, above.
404	M3 Screws, Thread Forming 	4	McMaster-Carr	96817A300	Used to attach the Nextion touch screen display to the 3D printed case.
405	Magnets 	4	McMaster-Carr or Amazon	5862K14	1/2" outside diameter with hole in center for attaching to an object via a screw. Used on bottom of the 3D-printed enclosure for the Nextion touch screen display
406	Sheet Metal Screws, #4, 3/4" long, round head 		McMaster-Carr	90935A137	These work acceptably in the MDF for the purposes they are designed to be used.
407	Particle Board Screws, #6, 3/4" long, round head 		McMaster-Carr	91555A115	
408	Particle Board Screws, #6, 5/8" long, flat head 		McMaster-Carr	90252A246	Used to attach #208, #209, and #210 to the MDF.
409	Sheet metal screws, #4, 5/16" long, flat head 		McMaster-Carr	90065A107	Used to attach #405 magnets to the 3D-printed enclosure for the Nextion touch screen display.
410	Torx Round Head Thread-Forming Screws for Plastic, #4, 7/8" long 		McMaster-Carr	96001A217	If you take option #2 as outlined in part 2, you should use these. If not, they are not needed.

MDF Rose Engine Lathe 2.0

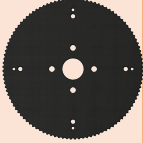
Build Instructions – Control System for Multiple Stepper Motors





Item #	Item	Qty	Source	Source Part Number	Comments
Spindle Drive Parts					
501	Timing Belt 	1	MiSUMi	GBN655EV5GT-90	<ul style="list-style-type: none"> • GT3 5mm pitch • 131T / 655mm long • 9mm wide
502	Spindle Pulley 	1	Colvin Tools		<p>Attached to the spindle via the flange.</p> <p>This can be 3D printed using the the designs at https://mdfre2.colvintools.com/3DPrint.html; however, this is provided for convenience only. We recommend a machined one like the one we provide.</p>
503	Stepper Motor Pulley 	1	Stock Drive Products (www.sdp-si.com)	A 6A55-012DF0908	<p>Aluminum Alloy Timing Pulley for .354 (9mm)" Wide Belt</p> <ul style="list-style-type: none"> • 5 mm (GT2) Pitch • 12 Teeth • 0.25" Bore • 2 Flanges / With Hub <p>Attached to the stepper motor</p>
504	Stepper Motor Attachment Bracket & Parts	1	Colvin Tools		<p>Includes:</p> <ul style="list-style-type: none"> • Bracket with Idler • Mounting bolts, nuts, and spacers to attach to headstock • Mounting screws to attach stepper motor

Item #	Item	Qty	Source	Source Part Number	Comments
Touch Screen Parts					
601	Touch Screen Case for Nextion 4.3", 3D printed	1	Colvin Tools		<p>Can also get plans to 3D print this from elfren's repository on GitHub. The folder is RoseEngine_SpindleAndAxis / Nextion / Enclosure_43</p> <p>Alternatively, the 3D printing designs are at https://mdfre2.colvintools.com/3DPrint.html.</p> <p>Use this with #203.</p>
602	Touch Screen Case for Nextion 7", 3D printed	1	Colvin Tools		<p>Alternatively, the 3D printing designs are at https://mdfre2.colvintools.com/3DPrint.html.</p> <p>Use this with #221.</p>

Not all screws are shown, only the ones which matter for size or are hard to find.

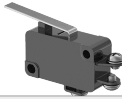
MDF Rose Engine Lathe 2.0

Build Instructions – Control System for Multiple Stepper Motors

Item #	Item	Qty	Source	Source Part Number	Comments
	Optional Parts				
901	Limit switch 	Up to 6	McMaster-Carr	7779K13	Needs to be normally off with a momentary on.
902	Magnetic base stand with Noga style arm 		Amazon		For holding the limit switch. Clockwise Tools MGBR-01 is a good one to consider. There is a bracket available in the 3D Printed Parts book which can be used to attach the limit switch to this (https://mdfre2.colvintools.com/3DPrint.html).
903	microSD extender 		Amazon		Needs to provide a male jack to plug into the Teensy, and a female jack for inserting the microSD card. Recommend one with a cable which is 10" to 12". There is a bracket available in the 3D Printed Parts book which can be used to attach this to a panel. It is in the parts for the <i>Control System for Multiple Stepper Motors</i> (https://mdfre2.colvintools.com/3DPrint.html).
904	Multilayer Ceramic Capacitor, 0.1 μ F 		Amazon		This is used to debounce the limit switch. It is recommended to attach one across the two leads at the limit switch (#901). These criteria are not critical, but the data listed at Amazon for these is: Capacitance Tolerance = $\pm 20\%$; Voltage = AC 50V; Lead Spacing = 5.08mm/ 0.2"; Temperature Range = +10C to +85C; Overall Size(Each) = 13x 5.7x 3mm/ 0.51" x 0.22" x 0.12"(L*W*T)
905	microSD card		Microcenter		32 GB is a good size. Do not get larger storage (e.g., 64 GB), but less is OK.
906	Cable Assembly, 3.5mm Plug 		Digi-Key	839-1039-ND	Use this to connect the limit switch to a plug. The pre-made cable makes this a whole lot easier. Vendor p/n 10-00344
907	microUSB / USB Cable				Need this to program the Teensy. Needs to handle both power and data.

MDF Rose Engine Lathe 2.0

Build Instructions – Control System for Multiple Stepper Motors

Section 1 – Attaching the Stepper Motor to the Headstock

The stepper motor attaches to the headstock as shown in the picture to the right.

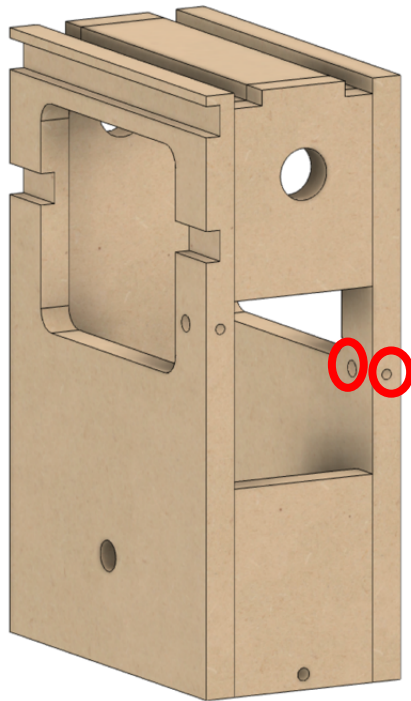

If you purchased the kit we supply, the holes on the left and right are already set properly. If you built it yourself, you will now need to drill the holes for the screws on the right. As noted in the case building instructions, these need to be set based on the alignment of the bracket.

- 502 Attach the spindle pulley to the spindle flange. There are 4 screws for this. One is indicated here.
- 504 Attach the stepper motor to the bracket using 4 screws. One is indicated here.
- 503 Secure the 12-tooth drive pulley to the stepper motor's spindle.

Attach the bracket to the headstock on both sides. There are two screws and two spacers (they look like thick washers). The spacers are installed between the bracket and the headstock. They are held onto the headstock using barrel nuts. Do not tighten them just yet.

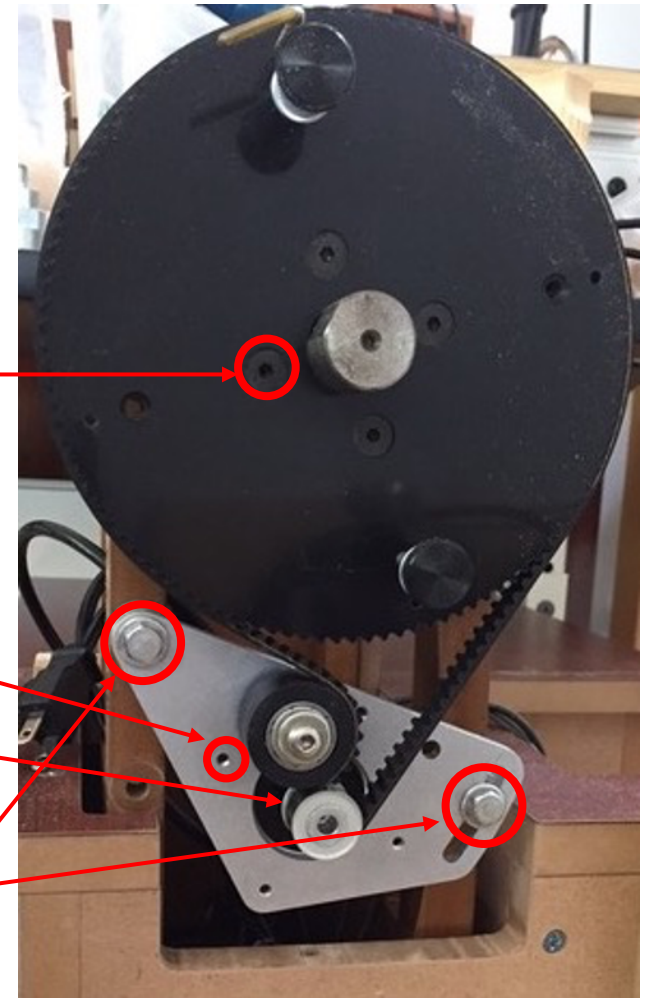

MDF Rose Engine Lathe 2.0

Build Instructions – Control System for Multiple Stepper Motors

NOTE: The picture on the right is of the assembly on the original MDF rose engine lathe. On version 2.0, there is no need for the cutout in the base to accommodate the bracket.

Install the timing belt (item #501).

Snug the bracket so that the timing belt is tight enough that it won't slip, but not so tight that it stretches. Once it is set, tighten the two bolts holding the bracket to the headstock. They need to be tight enough to not slip, but don't over tighten them as that will cause the barrel nuts to pull thru the MDF.

The stepper motor's cable needs to be fed thru the hole in the back of the headstock, and continue out of the lathe thru the hole in the back of the bed.

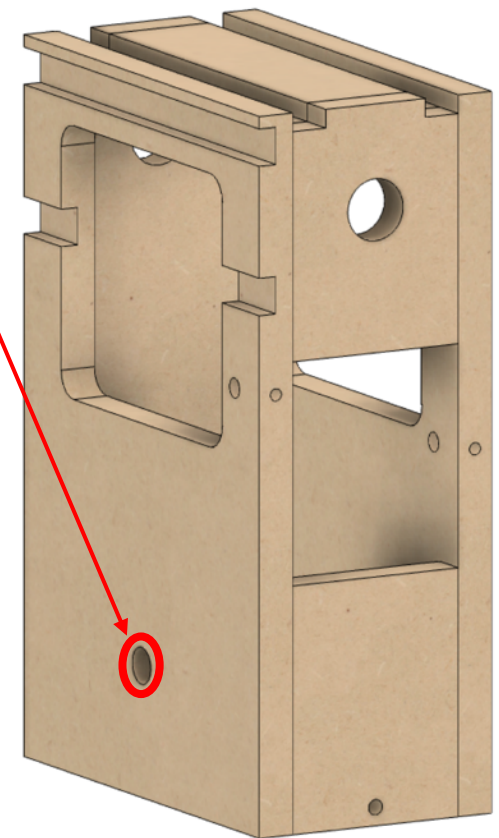
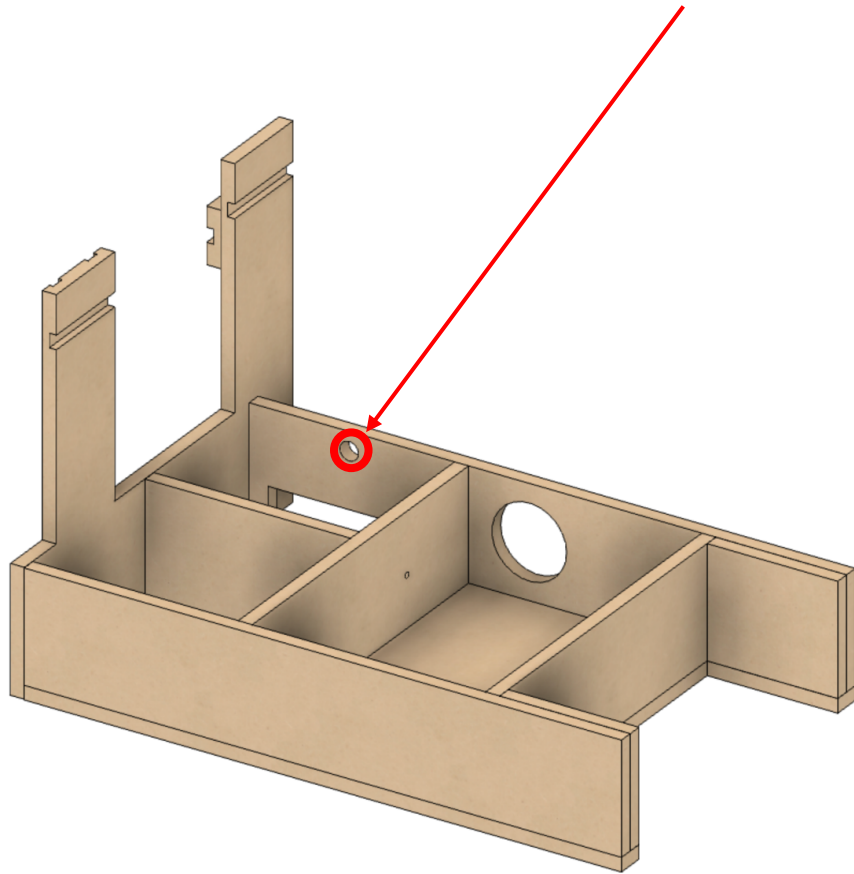

MDF Rose Engine Lathe 2.0

Build Instructions – Control System for Multiple Stepper Motors

Optional Configurations

If you wish to change the designs built into this system, options are outlined below. **We do not support systems with such changes, so the user must be aware that they will be responsible for their own technical support.** These options are only provided for the sake of completeness and transparency.

Option 1: Less Functional Model

Some have expressed the desire to build a system which is not as fully functional as outlined in this document. For example, they only want to drive the spindle.

That is very doable but is not an option we will be providing. The components which can be left out when building the system are outlined in the table below.

Regarding limit switches, none are truly required. These can be added later as desired. If not used, the 3.5mm audio jacks are not needed.

Component	Configuration			
	Spindle Drive Only	+ Z Axis	+Z & B Axes	+Z, X, and B Axes
10 K Ω Resistors	4	4	8	8
74HCT245s & 20-pin DIP sockets	1	1	2	2
DM542T Stepper motor drives & GX-16/4 Jacks	1	2	3	4

Recommendation

Except for the DM542T Stepper Motor Drives, there really is not any significant cost advantage to taking this approach. So, if you do desire to make such a change, consider populating the Printed Circuit Board fully (8 resistors and two 74HCT245s). The DM542Ts can be added when you later want to expand to use them.

MDF Rose Engine Lathe 2.0

Build Instructions – Control System for Multiple Stepper Motors

Option 2: Alternative Stepper Motor Drives

The printed circuit board was developed to use either

- the DM542T external drives outlined above, or
- the Pololu DRV8825 stepper motor drives which would be attached to the board using header sockets.

Advantages to Using the Pololu DRV8825

1. DRV8825s are about 1/3 the cost of an external drive (i.e., the DM542T).
2. Having the DRV8825s mounted to the printed circuit board makes for a smaller physical footprint, enabling it to be installed easily inside the lathe's bed carcass.
3. The power draw for this configuration is lower, so a different (& potentially less expensive) power supply is possibly available.
4. There is less cabling to be done.

Disadvantages of Using the Pololu DRV8825

1. DRV8825 chips are limited to a max 1.5 A (vs. 4.2 A for the DM542T drives).
 - a. This can necessitate the need for different, more expensive stepper motors. The cost of these different motors can erode the savings for not using the external stepper motor drives (DM542T).
 - b. It is easy to overload the DRV8825 chips and cause them to fail.
 - c. It is easy to overload the DRV8825 chips and they in turn can cause other components to fail (e.g., the Teensy).
2. DRV8825 chips get hot when used, so fans must be attached to them to ensure they do not overheat. And the user will need to replace the fans when they fail.
3. Future deliverables (e.g., a curvilinear slide and a spherical slide) for the MDF Rose Engine Lathe 2.0 will be tested to ensure compatibility with the design from above. If the add-on devices do not work with the changed configuration, the owner/builder will be responsible for accommodating the necessary changes.

Recommendation

Unless you are an electrical / automation engineer or have substantial experience in this space, the design outlined with external stepper motor drives will be easier to implement over the long term.

MDF Rose Engine Lathe 2.0

Build Instructions – Control System for Multiple Stepper Motors

Option 3: Different Microcontroller

The printed circuit board was developed to use either

- the Teensy 3.5 outlined above, or
- the Teensy 3.6.

The Teensy 3.6 is 50% faster than the 3.5; however, it will only accommodate 3.3V whilst the Teensy 3.5 will accommodate 5V. Using the 3.5 helps ensure you don't burn out the microcontroller.

As for Teensy 4.0 or 4.1, the library of functions needed to control the stepper motor drives is not yet complete for those boards. We will re-evaluate those over time.

Recommendation

Unless you are an electrical / automation engineer or have substantial experience in this space, the design outlined with a Teensy 3.5 is recommended.

MDF Rose Engine Lathe 2.0

Build Instructions – Control System for Multiple Stepper Motors

Option 4: Different Display

The control system was designed for a Nextion display. We provide the code for

- The original 4.3” Enhanced display,
- The 5” Intelligent display, and
- The 7” Intelligent display.

Recommendation

If you want to use a 3D printed display, use the Nextion 4.3” Intelligent display. If you are getting older, the 7” display is nice; however you will have to design your own case to hold it.

MDF Rose Engine Lathe 2.0

Build Instructions – Control System for Multiple Stepper Motors

Document Version History

Ver	Date	Comment
4.0	01 Aug 22	<ul style="list-style-type: none">Added parts #118, #119, #120, #222, and #907.Updated information regarding Nextion 5” & 7” displays.
3.2	22 Jan 22	<ul style="list-style-type: none">Added parts #219, #220, #221, #602, #905, and #906.Updated commentary on #207.
3.1	30 Nov 21	<ul style="list-style-type: none">Updated BOM to only be in this document. Also added pictures.
3.0	19 Aug 21	<ul style="list-style-type: none">Original document split into 3 parts to allow for different case configurations to be handled easily.
2.1	14 Aug 21	<ul style="list-style-type: none">Changed pins used for limit switchesAdded information regarding different Teensy and Nextion displays.
2.0	13 Jun 21	<ul style="list-style-type: none">This document incorporates changes to the way cables are attached to the PCB. It now shows how to use connectors in lieu of soldering the wires directly to the board.
1.4	10 Mar 21	<ul style="list-style-type: none">Reorganized a few steps to follow better flow of work.Added notes on using GX-12/4 connector for Nextion display.Updated instructions for loading software to reference web site.Also added a few minor other tweaks.
1.3	01 Jan 21	<ul style="list-style-type: none">Added item numbers for optional build using a Pololu Tic (this is a separate document).Renamed Document
1.2	15 Dec 20	<ul style="list-style-type: none">Added parts to the bill of materialsAdded details on the installation of the 3.5mm phono jacks.
1.1	10 Dec 20	<ul style="list-style-type: none">Added details for optional configurations.Added information for attaching the stepper motor to the headstock
1.0.2	07 Dec 20	<ul style="list-style-type: none">Updated p/n for item #204; also updated p/n & qty for item #102.Added note on soldering on 3.5mm jacks first.
1.0.1	05 Dec 20	<ul style="list-style-type: none">Updated commentary about stepper motor needed.Added information about stepper motor mount, pulleys, and belt.Updated drawing dimensions.
1.0	01 Dec 20	Initial document

To the extent that material may appear to be infringed, we assert that such alleged infringement is permissible under fair use principles in U.S. copyright laws. If you believe material has been used in an unauthorized manner, please contact me at ColvinTools@Gmail.com.

The layout of the Printed Circuit Board (PCB) is copyright Ed French and is used with his permission.

Permission is not granted to manufacture these for sale.